



Rohde & Schwarz Products: R&S® CBT/CBT32 (B55, K55), R&S® CBTgo
 R&S® SMU, R&S® SMJ, R&S® SMATE, R&S® SMR, R&S® FSU, R&S® FSQ, R&S® FSP, R&S® FSL

Measurements on Bluetooth® Products In Accordance With The Test Specification* (Version 2.0 + EDR)

Application Note

Nearly all tests in accordance with the test specification* can be performed with the R&S® CMU200/CBT alone. Some tests additionally call for signal generators to provide interference signals and also require spectrum analyzers. This application note describes the tests performed with additional equipment and presents straightforward solutions based on the CBTgo software.

* RF Test Suite Structure and Test Purposes System Specification 2.0 + EDR, Revision 2.0.E.3



Contents

1	Overview	3
2	General.....	3
	Software Features of CBTgo	3
	PC Hardware and Software Requirements	4
	Hardware requirements	4
	Software requirements.....	4
	Operation of CBTgo	4
	<i>Bluetooth Call Setup</i> module	4
	<i>Bluetooth Call Release</i> module.....	6
	<i>Bluetooth Power Step</i> module	7
	Prepare for Operation	8
	Setting the GPIB parameters in CBTgo.....	8
	Setting the reference frequency in CBTgo.....	9
	Measuring the attenuation values	9
3	Stipulated Measurements	10
	Power Density (5.1.4 TRM/CA/02/C)	10
	C/I Performance (5.1.18 RCV/CA/03/C)	13
	Blocking Performance (5.1.19 RCV/CA/04/C)	16
	Intermodulation Performance (5.1.20 RCV/CA/05/C).....	20
	EDR C/I Performance (5.1.24 TP/RCV/CA/09/C).....	24
4	Appendix	28
	Figures	28
	Tables	29
	References.....	29
5	Additional Information	29
	Ordering information	29

The following abbreviations are used in this application note for Rohde & Schwarz test equipment:

- The R&S® CBT Bluetooth tester is referred to as the CBT.
- The R&S® SMR microwave signal generator is referred to as the SMR.
- The R&S® SMJ100A vector signal generator is referred to as the SMJ.
- The R&S® SMATE200A vector signal generator is referred to as the SMATE.
- The R&S® SMU200A vector signal generator is referred to as the SMU.
- The R&S® FSP spectrum analyzer is referred to as the FSP.
- The R&S® FSU spectrum analyzer is referred to as the FSU.
- The R&S® FSQ signal analyzer is referred to as the FSQ.
- The R&S® FSL spectrum analyzer is referred to as the FSL.

The R&S logo, "Rohde & Schwarz", and "R&S" are registered trademarks of Rohde & Schwarz GmbH & Co. KG and its subsidiaries.

The Bluetooth word mark and logos are owned by the Bluetooth SIG, Inc. and any use of such marks by Rohde&Schwarz is under license.

1 Overview

The CMU200 universal radiocommunication tester can be used to perform fast and accurate measurements of different standards such as GSM, IS-136, AMPS, CDMA, CDMA2000, 1xEV-DO, WCDMA, HSPA and Bluetooth. The CBT is the "little brother" of the CMU and specially configured to Bluetooth requirements. The CBT comes in two versions: the CBT with display and the CBT32 without display.

Most of the tests in accordance with the V2.0 + EDR Rev. 2.0.E.3 RF test specification [1] can be performed by the CMU/CBT alone. Test solutions using the CMU/CBT with the CMUgo/CBTgo software were presented in the application note 1CM50 [3]. Some tests require additional equipment such as signal generators and/or spectrum analyzers. These tests include:

- Power density (5.1.4 TRM/CA/02/C)
- C/I performance (5.1.18 RCV/CA/03/C)
- Blocking performance (5.1.19 RCV/CA/04/C)
- Intermodulation performance (5.1.20 RCV/CA/05/C)
- EDR C/I performance (5.1.24 TP/RCV/CA/09/C)

This application note describes the use of CBTgo, which is a free of charge Windows application program for remote control of the CBT, for the tests requiring additional equipment, such as an SMU/SMJ/SMR (abbreviated SMx) vector signal generator and/or an FSU/FSQ/FSP/FSL (abbreviated FSx) spectrum or signal analyzer.

This means that the CBT with CBTgo is now capable of performing *all* tests in accordance with the test specification. Using the CBT and CBTgo, development engineers can thus optimally prepare their products for qualification.

Note:

The CBT and CBTgo require the CBT-K55, -B55 or -U55 options to support the V2.0 + EDR functionality.

2 General

Software Features of CBTgo

The CBTgo software features a straightforward user interface for remote control of the CBT via the GPIB-bus (IEEE488.2) or the RS-232-C interface.

CBTgo offers separate, preconfigured modules that can be combined to form test sequences. This requires no knowledge about remote programming.

CBTgo allows test reports to be output. Reports of remote commands can also be output, stating the times of the individual steps, and such reports can be copied to the Windows clipboard for further use.

PC Hardware and Software Requirements

Hardware requirements

- CPU: at least 300 MHz
- RAM: at least 64 Mbyte
- Monitor: SVGA with 800 x 600 pixels or higher
- Hard disk: 50 Mbyte available space
- Peripherals: National Instruments GPIB-bus or RS-232-C interface, mouse

Software requirements

- Windows 98/ME/2000/XP
- CBTgo V1.91 with V1.91 Bluetooth modules

Operation of CBTgo

Please refer to the CBTgo manual [2] for information on how to connect the computer with the CBT, as well as how to install, start and operate CBTgo.

All new modules presented here require other CBTgo modules to operate. For these basic modules, detailed descriptions already exist (see [3]); only the main settings will therefore be described in this document.

Each test sequence requires the *Basic Initializing* and the *BT Call Setup* module for call setup, and the *BT Call Release* module for call release. The *BT Power Step* module may also be required in order to step the DUT up to maximum power.

Bluetooth Call Setup module

The *BT Call Setup* module is required at the start of each Bluetooth test sequence (after *Basic Initializing*). The main parameters for setting up a call to a Bluetooth device are set in this module (Fig. 1).

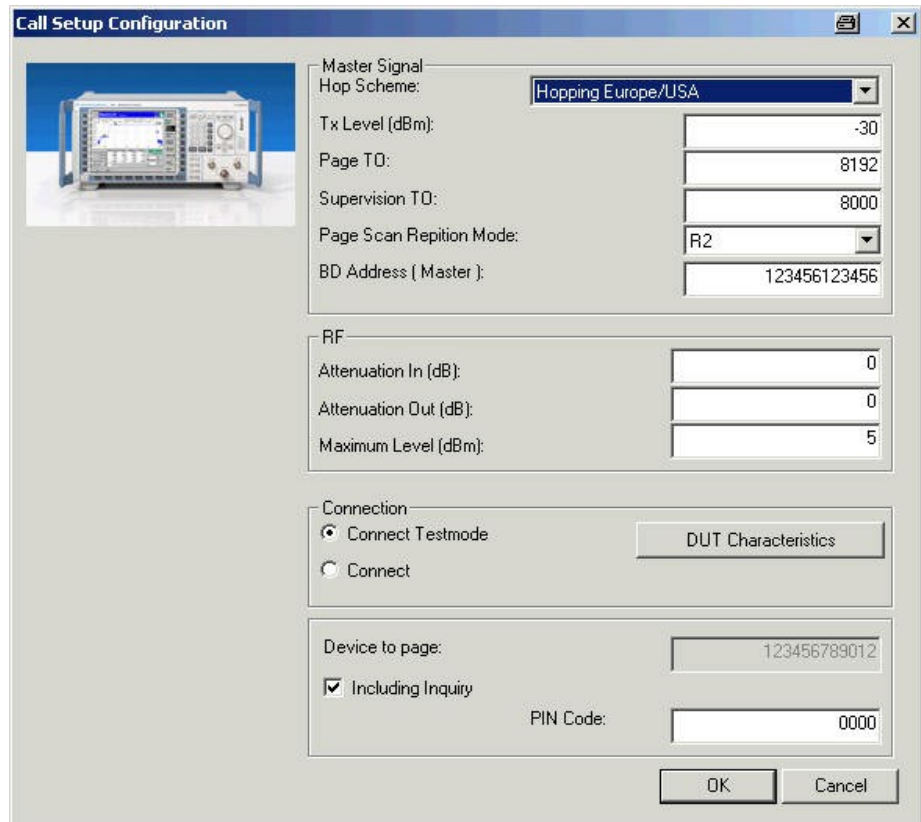

Fig. 1 - Call Setup Configuration

Under **Master Signal**, the parameters for the downlink, i.e. from the CMU200 to the Bluetooth device, are set.

Under **RF**, you can enter the attenuation between the CBT and the DUT. The settings made here will be valid throughout the Bluetooth test sequence, i.e. attenuation values cannot be varied during a sequence.

IMPORTANT! *Maximum Level* should be selected 5 dB above the expected power level of the Bluetooth device. The default setting of 5 dBm is valid for a class 2 device with a nominal output power of 0 dBm.

Under **Connection**, select *Connect Testmode*. In this mode, CBTgo establishes a call to the Bluetooth device and then automatically switches to the test mode. Please note that the Bluetooth module may first have to be externally enabled for the test mode.

Moreover, you can set the address of the device to be paged either directly or find the address by way of an inquiry. The inquiry is stopped when the first Bluetooth device address is found, and the first address is used to set up a call. A PIN code can be entered in addition.

If *Connect Testmode* is selected, further parameters can be set under *Slave Signal*.

Fig. 2 shows a typical entry for *Call Setup* in the test report.

General

Test Name and Condition	Lower Limit	Upper Limit	Measured Value	P/F
Country: Hopping Europe/USA, Tx Level: -30.0 dBm, Attenuation (In/Out): 0.0/0.0 dB, Max. Level: 5.0, Page Scan Repetition Mode: R2				
Hop Scheme: Hopping Europe/USA, Packet Type: DH1, Length of Testsequence: 27				
Default Device Address: 123456789012, Inquiry: Done				
BD Address (CMU): 123456123456, Test Scenario: Loopback ACL not whit - 1010 Pattern				
Name: Demo, LMP Version: 1.1, Company ID: Ericsson, Version: 123, BD Address: 1234567890				
Connection to Device:			passed	✓

Fig. 2 – Test report: Bluetooth Call Setup

Bluetooth Call Release module

The *BT Call Release* module is used to release an existing call to a Bluetooth device; the CBT goes to the standby mode (Fig. 3).

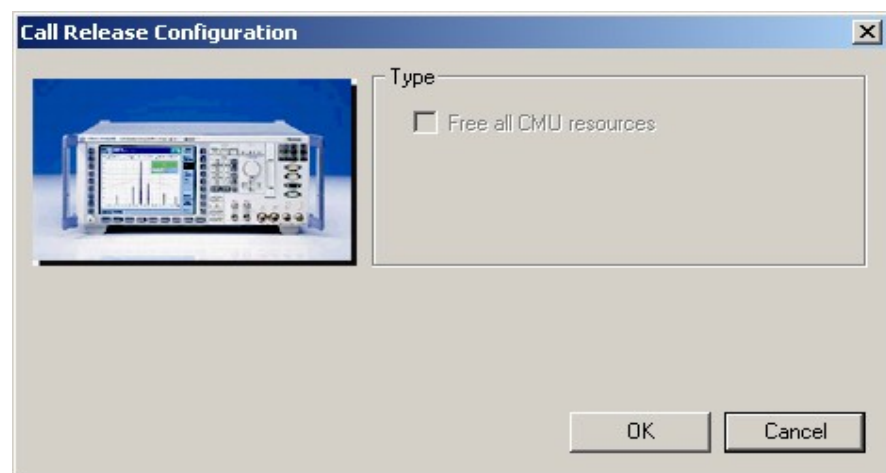

Fig. 3 - Call Release Configuration

Fig. 4 shows the entry for *Call Release* in the test report.

Detach device:			passed	✓
----------------	--	--	--------	---

Fig. 4 – Test report: Bluetooth Call Release

If no call has been set up to the Bluetooth device or the call has been disconnected, a warning is output (Fig. 5). This warning is – if applicable – also output by all other Bluetooth modules (except for *BT Call Setup*).



Fig. 5 – Warning: Bluetooth connection lost!

Bluetooth Power Step module

This module is required only if the DUT has to be stepped up to maximum output power.

Power Step offers four alternatives for power control of the Bluetooth device (Fig. 6).

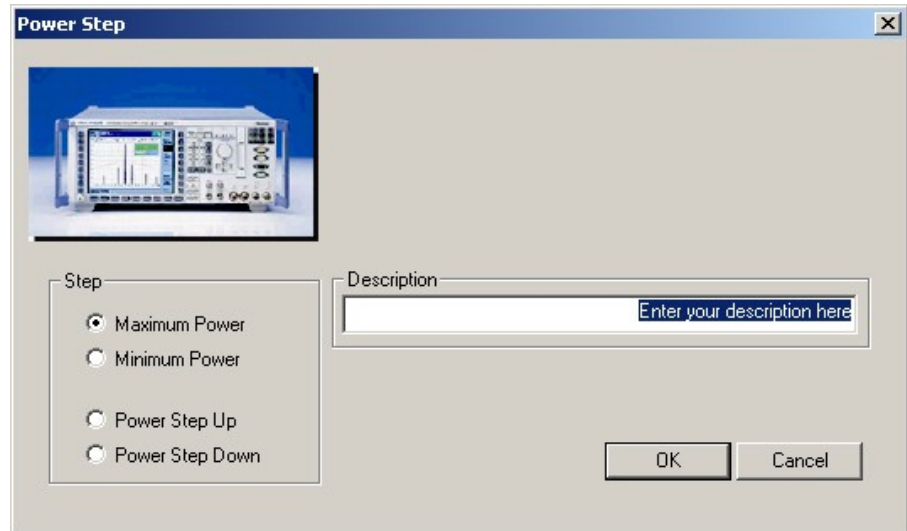

Fig. 6 - Power Step

The tester first inquires, via the signaling information, whether the Bluetooth device supports power control. If this is not the case, a warning is output (Fig. 7).



Fig. 7 - Warning: Power control not supported by the device

If power control is supported, various operations can be performed. *Maximum Power* and *Minimum Power*, for example, step the power up or down until the Bluetooth device under test signals that it is transmitting at maximum or minimum power level.

Fig. 8 shows a typical entry for *Power Step* in the test report.

Power Step: Maximum
Limit reached!

Fig. 8 – Test report: Power Step

Prepare for Operation

Setting the GPIB parameters in CBTgo

The GPIB parameters of the CBT can be set via CONFIGURATION|REMOTE PORT. CBTgo uses auxiliary channels in order to communicate with additional devices.

To configure an additional device, open the **Configuration** menu (Fig. 9) and select an *Auxiliary GPIB Port*. A window with further parameters will open (Fig. 10).

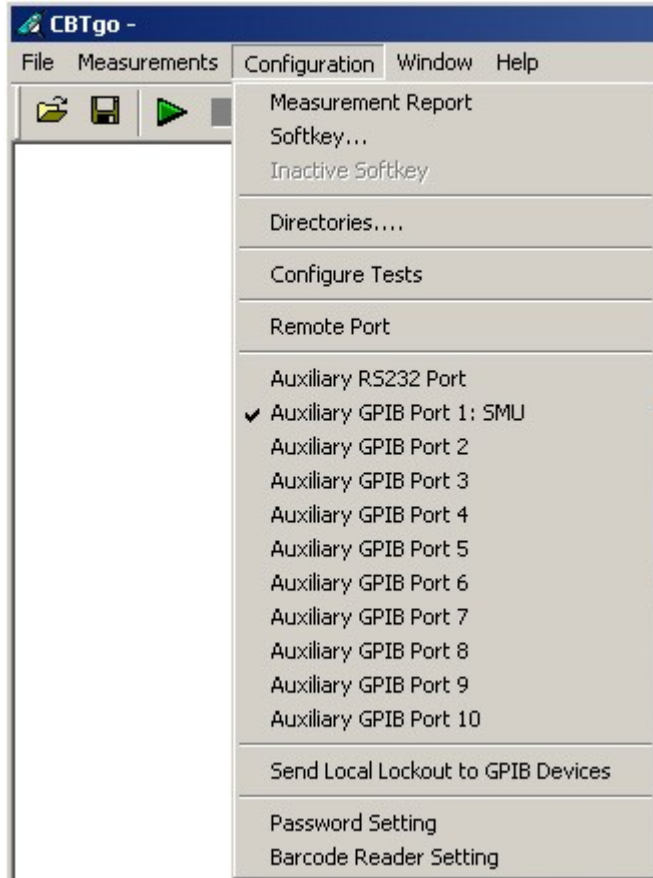

Fig. 9 - Configuration menu

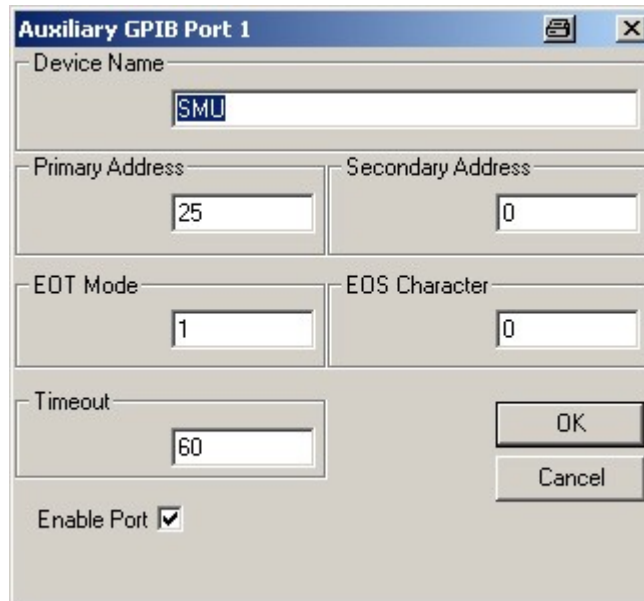

Fig. 10 - Auxiliary GPIB Port x

The device name entered under *Auxiliary GPIB Port x* must be identical to the name entered in the Bluetooth modules for the individual tests. The usual GPIB parameters can be set. Note that *Enable Port* must be activated.

Setting the reference frequency in CBTgo

Via the *Basic Initializing* module, the CBT can be synchronized with other equipment using a 10 MHz clock signal. For this purpose, activate *External 10 MHz Reference* (Fig. 11), and connect a BNC cable between the REF OUT output of a generator/analyzer and the REF IN socket of the CBT.

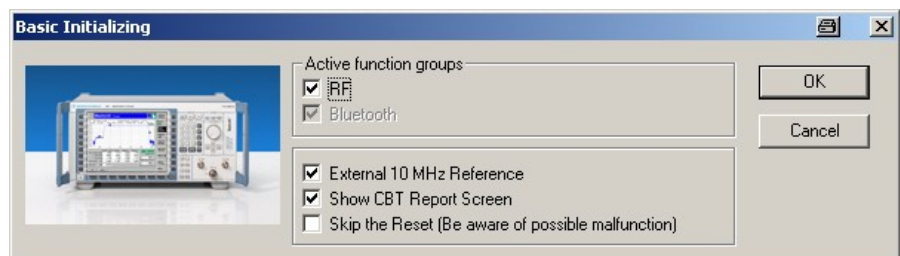

Fig. 11 – Activating the external 10 MHz reference

Measuring the attenuation values

To obtain correct results, the attenuation between the CBT and the DUT must be measured and entered into the *BT Call Setup* module. Likewise, the attenuation between the DUT and the signal generator(s) and/or the spectrum analyzer must be measured and entered into the appropriate module(s).

Rohde & Schwarz also offers the free-of-charge **FreRes** software which allows to record the frequency response. It is available under the following link:

<http://www.rohde-schwarz.com/appnote/1MA09>

3 Stipulated Measurements

Power Density (5.1.4 TRM/CA/02/C)

This measurement determines the maximum transmit power of the device under test.

The CBT causes the DUT to send the wanted signal in hopping mode (i.e. on all channels) and measures the DUT output power versus a specific frequency range (Fig. 12).

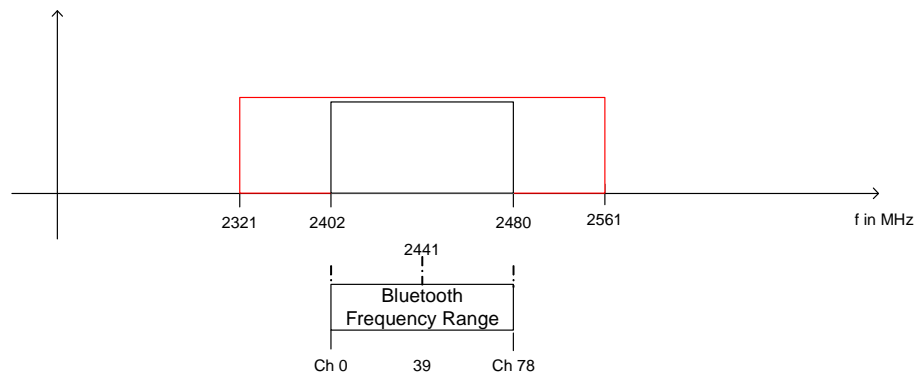

Fig. 12 - Power density

The Bluetooth test specification defines the following **settings**:

- Loopback or TX mode
- Hopping on
- TX at maximum power
- Longest possible packet type
- PRBS9
- Spectrum analyzer:
 - Center frequency: 2441 MHz
 - Span: 240 MHz
 - RBW: 100 kHz
 - Video BW: 100 kHz
 - Peak detector
 - Max Hold
 - Sweep time: 1 s per 100 kHz

Stipulated Measurements

Results:

1st test run: The frequency with maximum power is determined.

2nd test run: The center frequency is set to the frequency found during the 1st test run. Another measurement is performed with zero span with a sweep time of 60 s. The transmit power must not exceed 20 dBm (100 mW).

Fig. 13 shows a typical result on the FSQ.

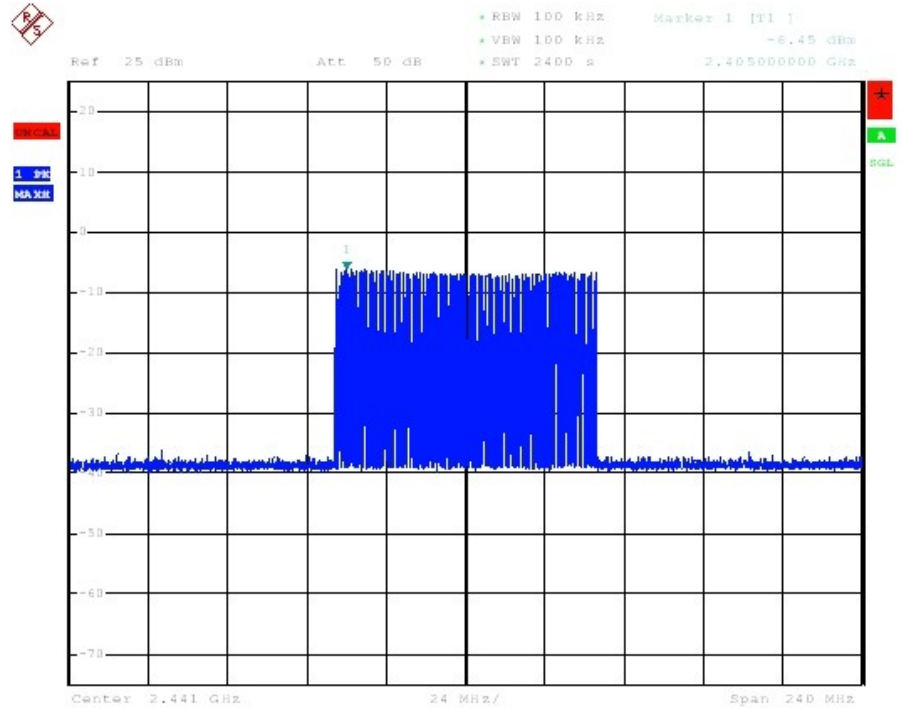

Fig. 13 - Power density, 1st test run

Test setup

Fig. 14 shows a typical test setup. The CBT and the DUT are connected to each other via a combiner, via which a spectrum analyzer is coupled in.

When using the FSL, note the following:

The maximum settable reference level on the FSL is 20 dBm. An attenuator must therefore be connected ahead of the spectrum analyzer.

Stipulated Measurements

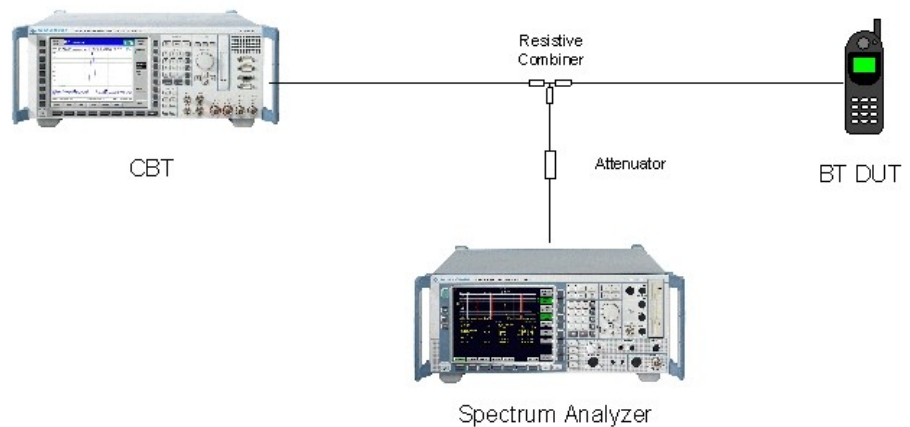

Fig. 14 – Test setup for power density measurement

Measuring equipment and accessories:

- CBT tester, FSx (FSU, FSQ, FSP, FSL) spectrum analyzer
- Resistive combiner: up to 2.5 GHz (e.g. Weinschel 1515-1)

The measurement is performed with the **BT Power Density** module of CBTgo (Fig. 15).

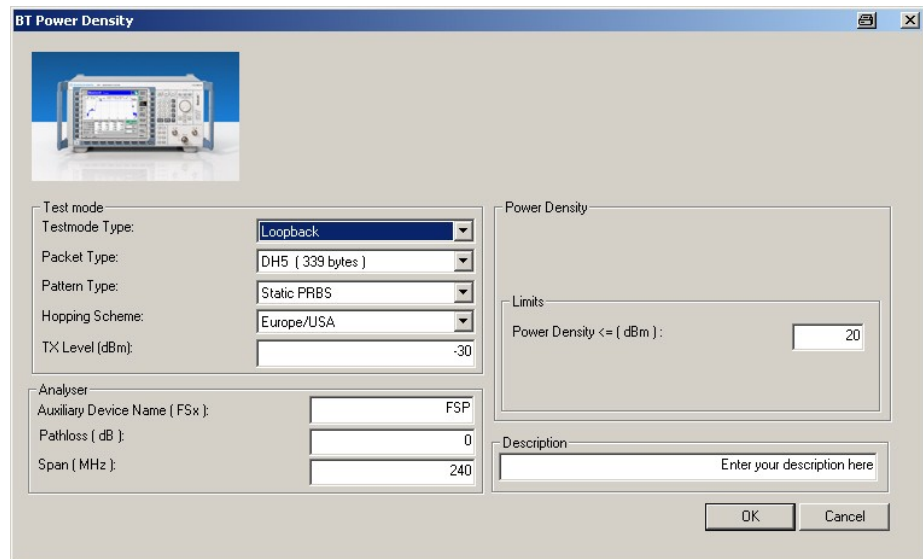

Fig. 15 - BT Power Density module

Under **Test mode**, you can select the test type, the packet type, the pattern type, the hopping scheme, and the CBT TX level.

Under **Analyser**, the auxiliary device name is to be entered. The name must be identical to that entered for *Auxiliary GPIB Port x* in the **Configuration** menu. Moreover, the path loss between the analyzer and the DUT as well as the span to be covered can be entered.

Under **Power Density** the limit for the transmit power is entered.

The default settings comply with the test specification.

Stipulated Measurements

CBTgo automatically performs the test with the selected settings.

In the first test run, the frequency with the maximum power is determined. In the second test run, which is also performed automatically, the power at this frequency is measured with zero span with a sweep time of 60 s.

With the settings in compliance with the test specification, the measurement time is approx. 41 minutes .

Fig. 16 shows a typical entry in the test report.

Hopping Scheme: EuropeUSA, Testmode: Loopback, Tx Level: -60.0 dBm

Pattern Type: SPRS, Packet Type: DH5

Generator: FSQ, Pathloss: 5.00 dB, Span: 240 MHz, Sweeptime per 100 kHz: 1s

Power Density : at 2.404136 GHz

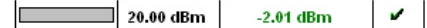

Fig. 16 – Test report: Power Density

C/I Performance (5.1.18 RCV/CA/03/C)

This measurement determines the receiver quality of the DUT if a Bluetooth interferer is present within the Bluetooth band. The result is obtained by means of a bit error rate (BER) measurement.

The wanted signal is transmitted on a single channel in non-hopping mode. A Bluetooth interferer is likewise generated on a single channel, coupled in, and the BER is determined. In the next step, the Bluetooth interferer is generated on all channels one after the other, and the BER is determined for each interferer channel. The complete test sequence is repeated twice, i.e. the BER measurement is performed with the wanted signal on three channels in total (Fig. 17).

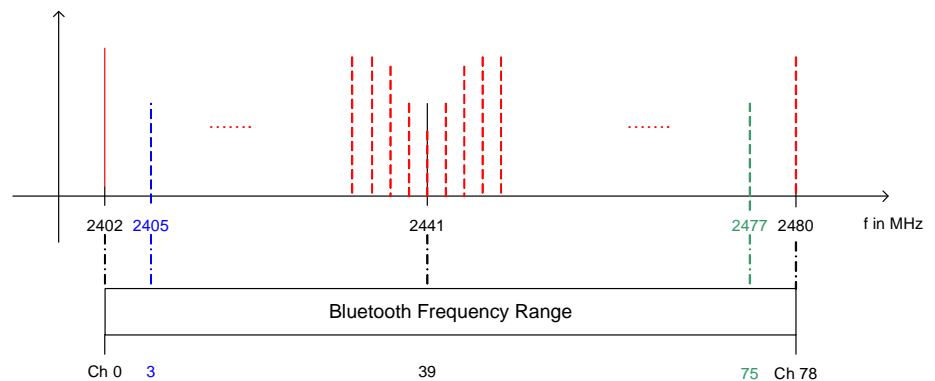

Fig. 17 - C/I performance

Stipulated Measurements

The Bluetooth test specification defines the following **settings**:

- Loopback mode
- Hopping off (RX/TX on single channel)
- Three channels (3, 39, 75)
- TX at maximum power
- DH1
- PRBS9
- Interferer: GFSK with PRBS15 on all Bluetooth channels in consecutive order
- 1,600,000 bit
- Reference level –70 dBm
- For levels see Table 1

Interferer Frequency spacing	Wanted signal Level, relative, above reference level	Wanted signal Absolute level	Interferer C / I	Interferer Absolute level
Co-channel	10 dB	-60 dBm	11 dB	-71 dBm
1 MHz	10 dB	-60 dBm	0 dB	-60 dBm
2 MHz	10 dB	-60 dBm	-30 dB	-30 dBm
≥3 MHz	3 dB	-67 dBm	-40 dB	-27 dBm
Image frequency	3 dB	-67 dBm	-9 dB	-58 dBm
Image frequency ± 1 MHz	3 dB	-67 dBm	-20 dB	-47 dBm

Table 1 – C/I performance levels

Results:

- For each of the three wanted channels, the BER may exceed 0.1 % for five interferer frequencies spaced ≥ 2 MHz from the carrier (test specification: "Spurious").
- For the interferer frequencies (max. five) at which the BER limit is exceeded, the BER is measured in a second test run with a C/I of –17 dB. The BER limit is again 0.1 %.

Test setup

Fig. 18 shows a typical test setup. The CBT and the DUT are connected to each other via a combiner, via which the interference signal from a Bluetooth generator is coupled in. If the DUT transmits at high power levels, an attenuator may be inserted to protect the generator.

Stipulated Measurements

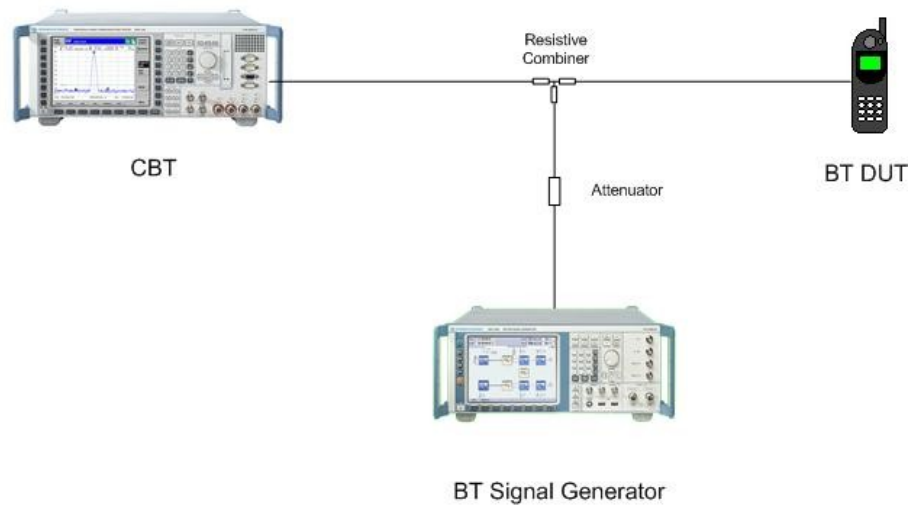

Fig. 18 – Test setup for C/I performance measurement

Measuring equipment and accessories

- CBT tester, SMx (SMU, SMJ, SMATE) signal generator
- Resistive combiner: up to 2.5 GHz (e.g. Weinschel 1515-1)
- Attenuator: up to 2.5 GHz (e.g. Suhner)

The measurement is performed with the **BT C/I Performance** module of CBTgo (Fig. 19).

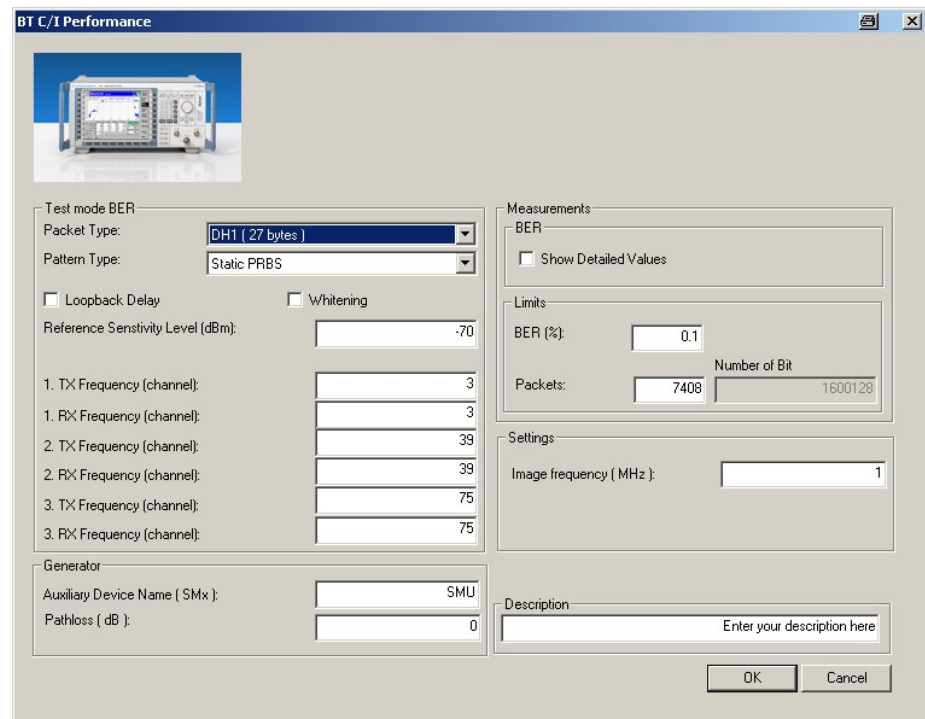

Fig. 19 - BT C/I Performance module

Stipulated Measurements

Under **Test mode BER**, you can select the packet type and the pattern type. *Loopback Delay* and *Whitening* can be activated. The RX and TX frequencies of the three channels can be set separately. The reference sensitivity level can be modified as required. The level of the wanted signal will be 3 dB or 10 dB above the set value, depending on the relative distance of the interferer signal (see Table 1).

Under **Generator**, the auxiliary device name is to be entered. The name must be identical to that entered for *Auxiliary GPIB Port x* in the **Configuration** menu. Moreover, the path loss between the generator and the DUT can be entered.

Under **Measurements**, you can enter the BER limit and the number of packets. From the packet type and the number of packets, CBTgo calculates the number of bits measured and displays it. Plus, you can enter the manufacturer-specific image frequency. The different levels are set automatically for measurements on the image-frequency channel (see Table 1).

The default settings comply with the test specification.

CBTgo automatically performs the test on the three channels with the selected generator settings.

In the first test run, all frequencies with a BER above the set limit are determined and displayed. In the second test run, which is also performed automatically, the DUT's performance at these frequencies is retested with a C/I of -17 dB.

If the connection is lost during the test, it will be re-established automatically, and "NAN" will be stated for the BER in the test report. If CBTgo fails to re-establish the connection for a period of 10 s, the test sequence will be stopped.

With the settings in compliance with the test specification, the measurement time is at least 40 minutes (10 s per BER measurement × 79 interferer channels × three wanted channels).

Fig. 20 shows a typical C/I performance test report.

Packet Type: DH1, Pattern: SPRS, Whitening: Off, Loopback Delay Off

Reference Sensitivity Level: -70.00 dBm, Packets: 7408, Number of Bit: 1600128

Generator: SMU, Pathloss: 0.00 dB, Interferer: GFSK, PRBS15, Image frequency: 1 MHz

Channel: 3

No spurious frequencies detected!



passed



Channel: 39

No spurious frequencies detected!



passed



Channel: 75

No spurious frequencies detected!



passed



Fig. 20 – Test report: C/I Performance

Blocking Performance (5.1.19 RCV/CA/04/C)

This measurement determines the receiver quality of the DUT if a CW interferer is present outside the Bluetooth band. The result is obtained by means of a bit error rate (BER) measurement.

The wanted signal is transmitted on a single channel in non-hopping mode. A CW interferer is likewise generated on a single channel, coupled in, and

Stipulated Measurements

the BER is determined. In the next step, the CW interferer is generated at intervals of 1 MHz in consecutive order over a specific frequency range, and the BER is determined for each interferer frequency (Fig. 21).

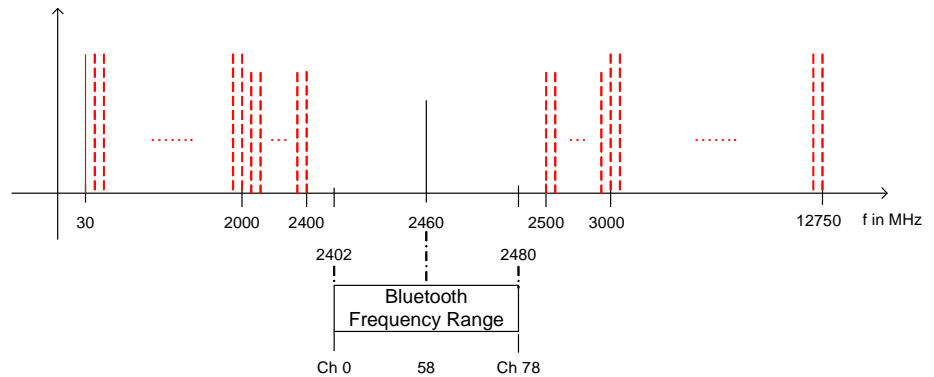

Fig. 21 - Blocking performance

The Bluetooth test specification defines the following **settings**:

- Loopback mode
- Hopping off (RX/TX on single channel)
- Single wanted channel (58)
- TX at maximum power
- DH1
- PRBS9
- Wanted signal level 3 dB above reference level (–70 dBm), absolute level: –67 dBm
- Interferer: CW in 1 MHz steps, for levels and frequency ranges see Table 2 and Table 3.

Results:

1st test run: At each interferer frequency, 100,000 bits are measured. The frequencies at which a BER > 0.1 % is obtained are recorded.

Interferer Frequency range	Interferer Absolute level
30 MHz to 2000 MHz	–8 dBm
2000 MHz to 2400 MHz	–25 dBm
2500 MHz to 3000 MHz	–25 dBm
3000 MHz to 12.75 GHz	–8 dBm

Table 2 - Blocking performance: levels for 1st test run

2nd test run: At each frequency recorded during the 1st test run, 1,600,000 bits are measured at reduced levels. The frequencies at which a BER > 0.1 % is obtained are again

Stipulated Measurements

recorded. The BER limit may be exceeded for a maximum of 24 frequencies.

Interferer Frequency range	Interferer Absolute level
30 MHz to 2000 MHz	-10 dBm
2000 MHz to 2400 MHz	-27 dBm
2500 MHz to 3000 MHz	-27 dBm
3000 MHz to 12.75 GHz	-10 dBm

Table 3 - Blocking performance: levels for 2nd test run

3rd test run: At each frequency recorded during the 2nd test run (max. 24), 1,600,000 bits are measured at an absolute interference level of -50 dBm. The BER limit of 0.1 % may be exceeded for a maximum of five frequencies.

Test setup

Fig. 22 shows a typical test setup. The CBT and the DUT are connected to each other via a combiner, via which the interference signal from a CW generator is coupled in. If the DUT transmits at high power levels, an attenuator may be inserted to protect the generator.

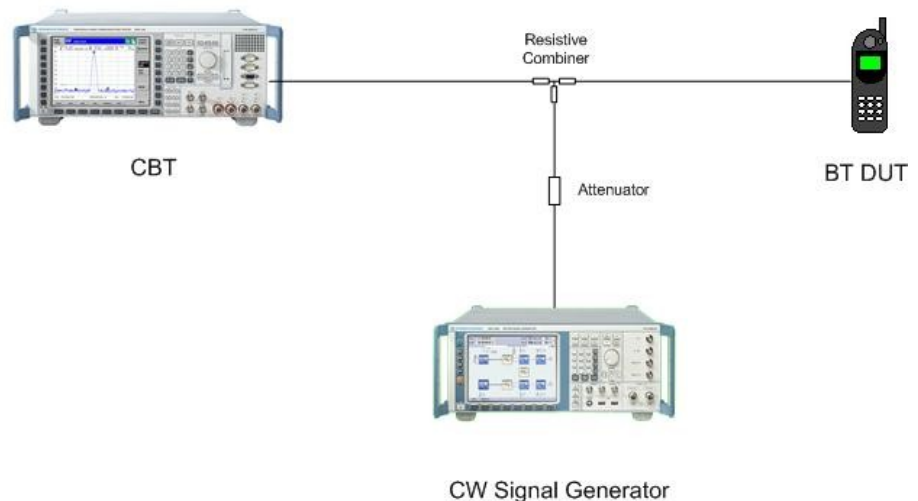

Fig. 22 – Test setup for blocking performance measurement

Stipulated Measurements

Measuring equipment and accessories

- CBT tester, SMx (SMR) generator up to 12.75 GHz
- Resistive combiner: up to 12.75 GHz (e.g. Weinschel 1515-1)
- Attenuator: up to 12.75 GHz (e.g. Suhner)

The measurement is performed with the **BT Blocking Performance** module of CBTgo (Fig. 23).

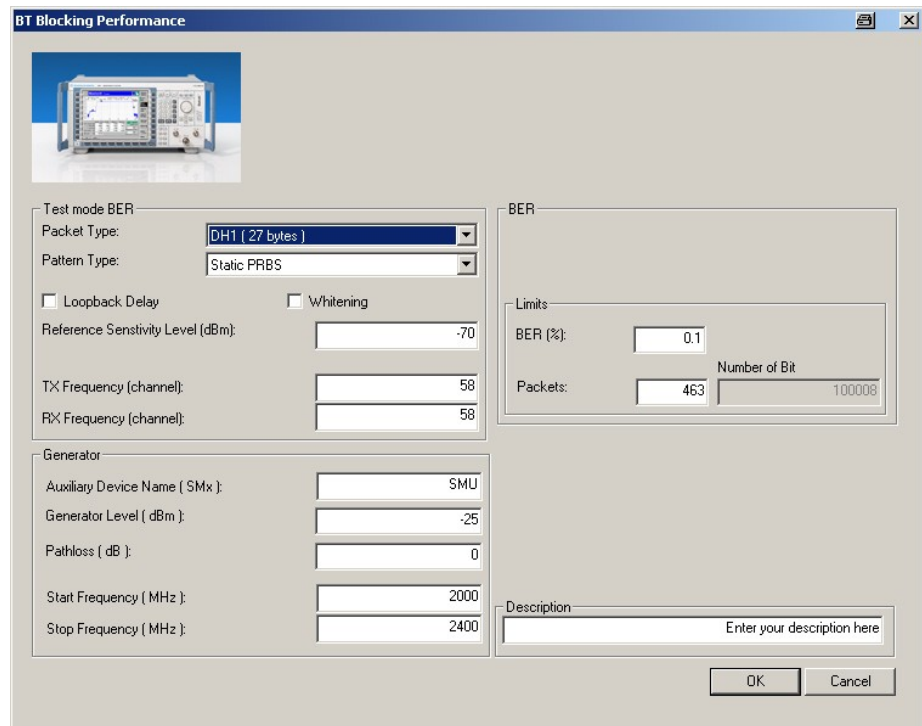

Fig. 23 - BT Blocking Performance module

Under **Test mode BER**, you can select the packet type and the pattern type. *Loopback Delay* and *Whitening* can be activated. The RX and the TX frequency of the measurement channel can be set separately. The reference sensitivity level can be modified as required. The level of the wanted signal will be 3 dB above the set value.

Under **Generator**, the auxiliary device name is to be entered. The name must be identical to that entered for *Auxiliary GPIB Port x* in the **Configuration** menu. Moreover, the path loss between the generator and the DUT can be set, and the generator level as well as a start and a stop frequency can be entered.

Under **BER**, you can enter the BER limit and the number of packets. From the packet type and the number of packets, CBTgo calculates the number of bits measured and displays it.

CBTgo automatically performs the test with the selected generator settings.

The blocking performance test comprises three test runs and is very time-consuming. For this reason, it is not performed fully automatically. Any additional frequency ranges and test runs that may be necessary must be

Stipulated Measurements

manually configured and started. Additional test runs can be performed on a single frequency by setting an identical start and stop frequency.

With the settings in compliance with the test specification, the measurement time is at least three hours and 30 minutes (1 s per BER measurement × approx. 12,600 interferer channels in the 1st test run).

Fig. 24 shows a typical entry in the test report.

Packet Type: DH1, Pattern: SPRS, Whitening: Off, Loopback Delay Off

Reference Sensitivity Level: -70.00 dBm, Packets: 463, Number of Bit: 100008

Generator: SMR, Pathloss: 5.00 dB, Generator Level: -25.00, Start frequency: 2000 MHz, Stop frequency: 2400 MHz

No spurious frequencies detected!



Fig. 24 – Test report: Blocking Performance

Intermodulation Performance (5.1.20 RCV/CA/05/C)

This measurement determines the intermodulation characteristic of the DUT's receiver. A BER measurement is performed with two interferers that cause intermodulation at the DUT's receive frequency.

The wanted signal is transmitted on a single channel in non-hopping mode. A CW interferer spaced $+n$ MHz and a Bluetooth interferer spaced $+2n$ MHz from the wanted signal are generated, coupled in, and the BER is determined. The measurement is then performed with the interferers at $-n$ MHz and $-2n$ MHz. The two measurements are repeated on two more wanted channels (Fig. 25).

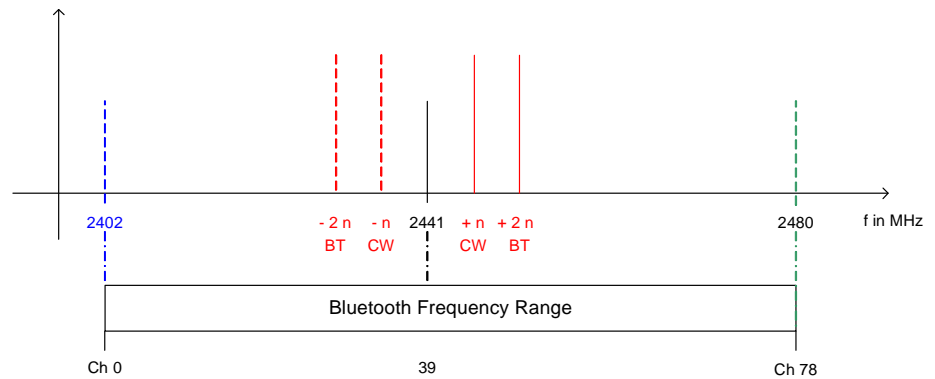

Fig. 25 - Intermodulation performance

Stipulated Measurements

The Bluetooth test specification defines the following **settings**:

- Loopback mode
- Hopping off (RX/TX on single channel)
- Three channels (0, 39, 78)
- TX at maximum power
- DH1
- PRBS9
- Wanted signal level 6 dB above reference level (–70 dBm), absolute level: –64 dBm
- $n = 3, 4$ or 5 (defined by manufacturer)
- Bluetooth interferer: GFSK with PRBS15 spaced $\pm 2n$ MHz from wanted signal, level –39 dBm
- CW interferer: spaced $\pm n$ MHz from wanted signal, level –39 dBm
- 1,600,000 bits

Result:

- A BER of $\leq 0.1\%$ must be obtained for each of the three channels.

Test setup

The two interferer signals required in this measurement are supplied via two generator paths, which are combined via a hybrid combiner. The resulting signal is coupled into the line connecting the CBT and the DUT via a second hybrid combiner. If a dual-channel SMU is used, one generator is sufficient (Fig. 26), otherwise two generators are required (Fig. 27).

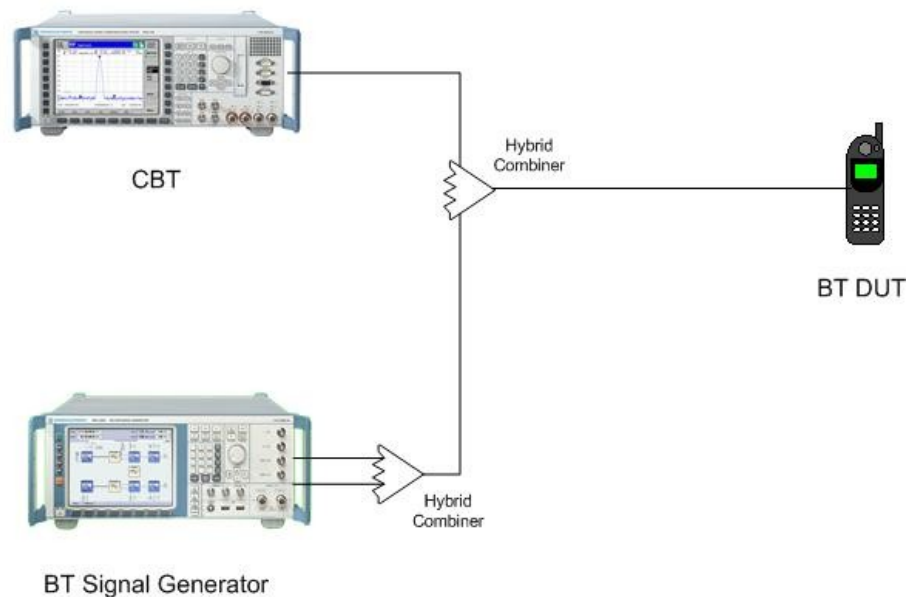

Fig. 26 – Test setup 1 for intermodulation performance measurement

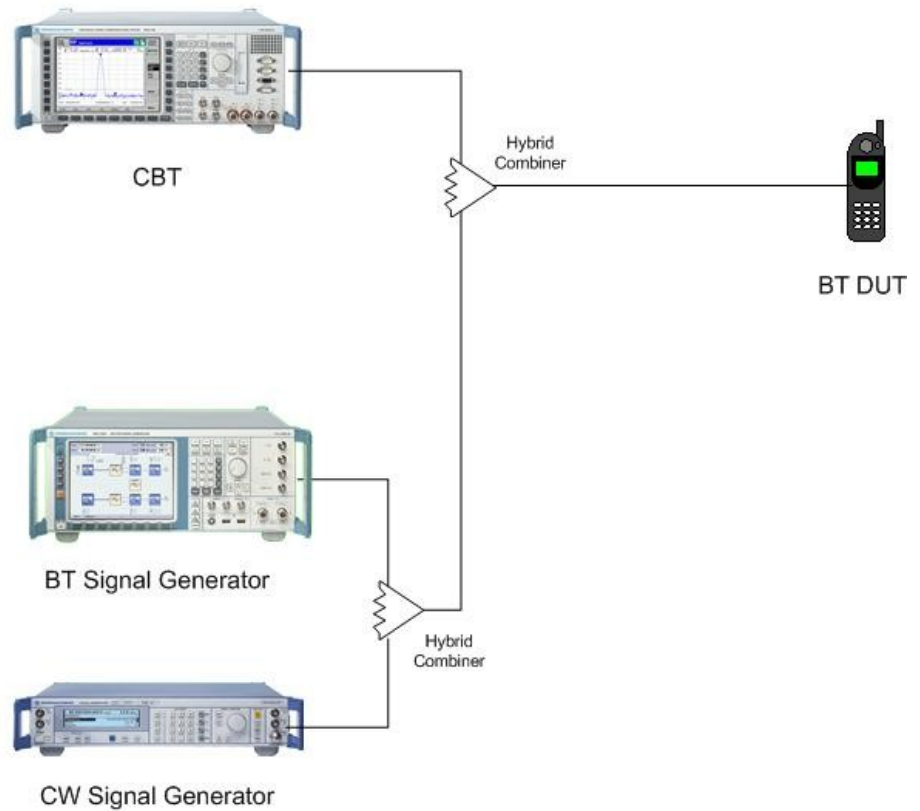

Fig. 27 – Test setup 2 for intermodulation performance

Measuring equipment and accessories

- CBT tester, SMU or SMJ + SMR signal generators
- Two hybrid combiners (e.g. Minicircuits ZFSC-2-2500)

The measurement is performed with the **BT Intermodulation Performance** module of CBTgo (Fig. 28).

Stipulated Measurements

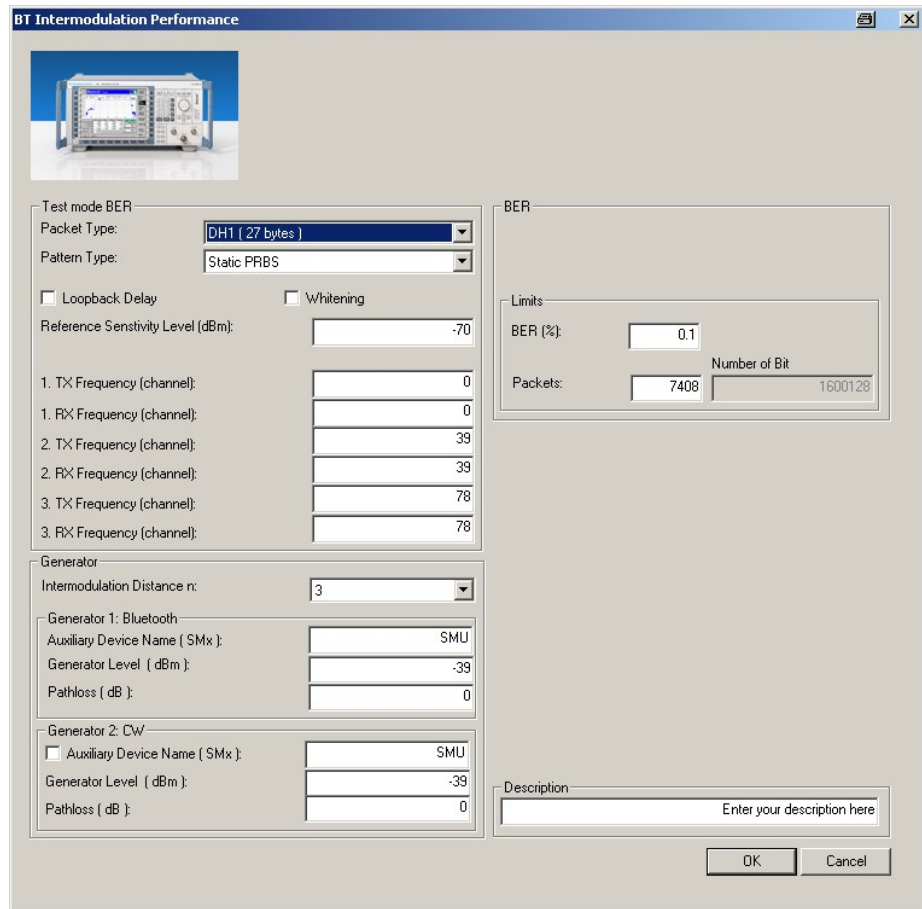

Fig. 28 - BT Intermodulation Performance module

Under **Test Mode BER**, you can select the packet type and the pattern type. *Loopback Delay* and *Whitening* can be activated. The RX and TX frequencies of the three channels can be set separately. The reference sensitivity level can be modified as required. The level of the wanted signal will be 6 dB above the set value.

Under **Generator 1** and **2**, the auxiliary device name is to be entered. The name must be identical to that entered for *Auxiliary GPIB Port x* in the **Configuration** menu. The intermodulation distance n (spacing from wanted signal) must be selected. Moreover, the path loss between the generator and the DUT as well as the interference level can be entered for each generator. A second generator can be included in the test setup if the first generator does not offer dual-channel capability.

Under **BER**, you can enter the BER limit and the number of packets. From the packet type and the number of packets, CBTgo calculates the number of bits measured and displays it.

The default settings comply with the test specification.

CBTgo automatically performs the test on the three channels with the selected generator settings.

Fig. 29 shows a typical entry in the test report.

Stipulated Measurements

Packet Type: DH1, Pattern: SPRS, Whitening: Off, Loopback Delay Off

Reference Sensitivity Level: -70.00 dBm, Packets: 7408, Number of Bit: 1600128

Generator: SMU, Pathloss: 10.00 dB, Interferer: GFSK, PRBS15, Distance n= 3

Channel: 0, 2402 MHz

BER : Interferer BT/ CW (MHz): 2396 , 2399



0.10 %

0.00 %



BER : Interferer BT/ CW (MHz): 2408 , 2405



0.10 %

0.00 %



Channel: 39, 2441 MHz

BER : Interferer BT/ CW (MHz): 2435 , 2438



0.10 %

0.00 %



BER : Interferer BT/ CW (MHz): 2447 , 2444



0.10 %

0.00 %



Channel: 78, 2480 MHz

BER : Interferer BT/ CW (MHz): 2474 , 2477



0.10 %

0.00 %



BER : Interferer BT/ CW (MHz): 2486 , 2483



0.10 %

0.00 %



Fig. 29 - Test report: Intermodulation Performance

EDR C/I Performance (5.1.24 TP/RCV/CA/09/C)

The EDR C/I Performance test essentially corresponds to the test described under

C/I Performance (5.1.18 RCV/CA/03/C). The test setup and sequence as well as the measuring equipment and accessories are identical. The two tests differ with respect to the packet type selectable for the wanted signal, the interfering signal, and the levels.

The Bluetooth test specification defines the following **settings**:

- Loopback mode
- Whitening on
- Hopping off (RX/TX on single channel)
- Three channels (3, 39, 75)
- TX at maximum power
- Longest possible packet type for each modulation mode
- PRBS9
- Interferer: GFSK with PRBS15 on all BT channels in consecutive order
 - Co-channel interferer: same modulation as wanted signal
- 1,600,000 bits
- Reference level – 70 dBm
- For levels see Table 4 and Table 5

Stipulated Measurements

Interferer Frequency spacing	Wanted signal Level, relative, above reference level	Wanted signal Absolute level	Interferer C/I	Interferer Absolute level
Co-channel	10 dB	-60 dBm	13 dB	-73 dBm
1 MHz	10 dB	-60 dBm	0 dB	-60 dBm
2 MHz	10 dB	-60 dBm	-30 dB	-30 dBm
≥ 3 MHz	3 dB	-67 dBm	-40 dB	-27 dBm
Image frequency	Same as above	Same as above	-7 dB	
Image frequency ± 1 MHz	Same as above	Same as above	-20 dB	

Table 4 – EDR C/I Performance for $\pi/4$ -DQPSK

Interferer Frequency spacing	Wanted signal Level, relative, above reference level	Wanted signal Absolute level	Interferer C/I	Interferer Absolute level
Co-channel	10 dB	-60 dBm	21 dB	-81 dBm
1 MHz	10 dB	-60 dBm	5 dB	-65 dBm
2 MHz	10 dB	-60 dBm	-25 dB	-35 dBm
≥ 3 MHz	3 dB	-67 dBm	-33 dB	-34 dBm
Image frequency	Same as above	Same as above	0 dB	
Image frequency ± 1 MHz	Same as above	Same as above	-13 dB	

Table 5 - EDR C/I Performance for 8DPSK

Results:

- For each modulation type, the BER may exceed 0.1 % for five interferer frequencies spaced ≥ 2 MHz from the carrier (test specification: "Spurious")
- For the interferer frequencies (max. five) at which the BER limit is exceeded, a BER of ≤ 0.1 % must be obtained for a C/I of -15 dB with $\pi/4$ -DQPSK and a C/I of -10 dB with 8DPSK.

The measurement is performed with the **BT EDR C/I Performance** module of CBTgo (Fig. 30).

Stipulated Measurements

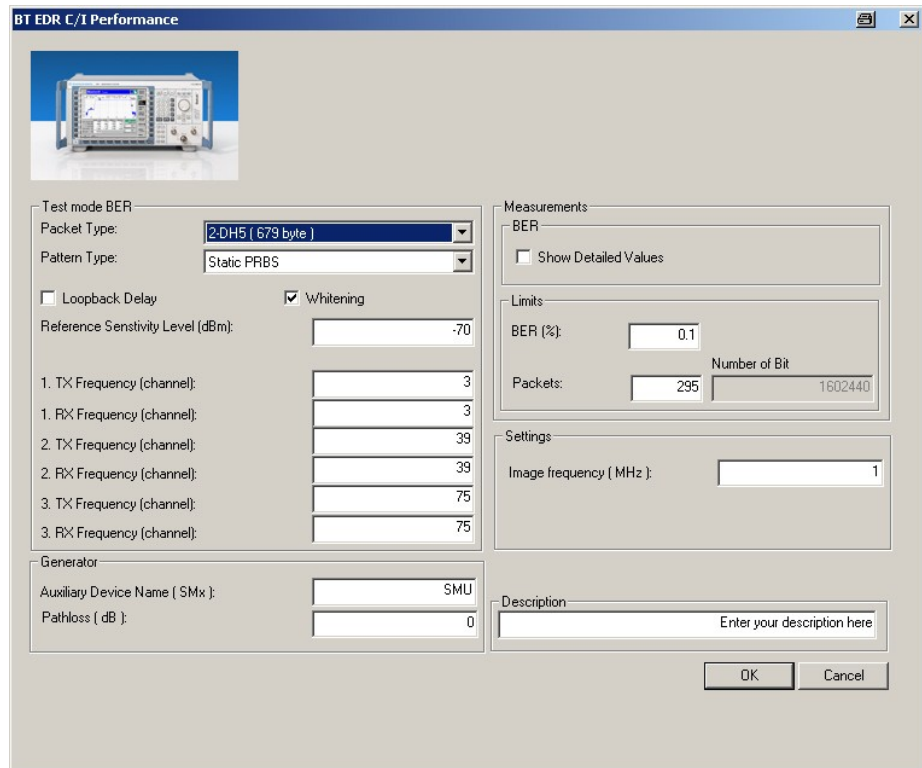

Fig. 30 - BT EDR C/I Performance module

Under **Test mode BER**, you can select the packet type (EDR packets only) and the pattern type. *Loopback Delay* and *Whitening* can be activated. The RX and TX frequencies for the three channels can be set separately. The reference sensitivity level can be modified as required. The level of the wanted signal will be 3 dB or 10 dB above the set value, depending on the relative distance of the interferer signal (see Table 4 and Table 5).

Under **Generator**, the auxiliary device name is to be entered. The name must be identical to that entered for *Auxiliary GPIB Port x* in the **Configuration** menu. Moreover, the path loss between the generator and the DUT can be entered.

Under **Measurements**, you can enter the BER limit and the number of packets. From the packet type and the number of packets, CBTgo calculates the number of bits measured and displays it. Plus, you can enter the manufacturer-specific image frequency. The different levels are set automatically for measurements on the image-frequency (see Table 4 and Table 5).

The default settings comply with the test specification (for $\pi/4$ -DQPSK). If the DUT supports 8DPSK packets, a second test must be performed.

CBTgo automatically performs the test on the three channels with the selected generator settings.

In the first test run, all frequencies with a BER above the set limit are determined and displayed. In the second test run, which is also performed automatically, the DUT's performance at these frequencies is retested with another C/I depending on the modulation type. If the connection is lost during the test, it will be re-established automatically, and "NAN" will be stated for the BER in the test report. If CBTgo fails to re-establish the

Stipulated Measurements

connection for a period of 10 s, the test sequence will be stopped and a warning will be output.

With the settings in compliance with the test specification, the measurement time is at least 10 minutes for $\pi/4$ -DQPSK packets (2.5 s per BER measurement \times 79 interferer channels \times three wanted channels) and at least 7 minutes for 8DPSK packets (1.8 s per BER measurement \times 79 interferer channels \times three wanted channels).

Fig. 31 shows a typical entry in the test report.

Packet Type: 2-DH5, Pattern: SPRS, Whitening: On, Loopback Delay Off

Reference Sensitivity Level: -70.00 dBm, Packets: 295, Number of Bit: 1602440

Generator: SIMU, Pathloss: 0.00 dB, Interferer: GFSK, PRBS15, Image frequency: 1 MHz

Channel: 3

No spurious frequencies detected!



passed



Channel: 39

No spurious frequencies detected!



passed



Channel: 75

No spurious frequencies detected!



passed



Fig. 31 – Test report: EDR C/I Performance

4 Appendix

Figures

Fig. 1 - Call Setup Configuration	5
Fig. 2 – Test report: Bluetooth Call Setup	6
Fig. 3 - Call Release Configuration	6
Fig. 4 – Test report: Bluetooth Call Release	6
Fig. 5 – Warning: Bluetooth connection lost!.....	6
Fig. 6 - Power Step.....	7
Fig. 7 - Warning: Power control not supported by the device.....	7
Fig. 8 – Test report: Power Step	7
Fig. 9 - Configuration menu.....	8
Fig. 10 - Auxiliary GPIB Port x.....	9
Fig. 11 – Activating the external 10 MHz reference	9
Fig. 12 - Power density.....	10
Fig. 13 - Power density, 1st test run	11
Fig. 14 – Test setup for power density measurement	12
Fig. 15 - BT Power Density module.....	12
Fig. 16 – Test report: Power Density.....	13
Fig. 17 - C/I performance	13
Fig. 18 – Test setup for C/I performance measurement	15
Fig. 19 - BT C/I Performance module	15
Fig. 20 – Test report: C/I Performance.....	16
Fig. 21 - Blocking performance	17
Fig. 22 – Test setup for blocking performance measurement	18
Fig. 23 - BT Blocking Performance module	19
Fig. 24 – Test report: Blocking Performance.....	20
Fig. 25 - Intermodulation performance	20
Fig. 26 – Test setup 1 for intermodulation performance measurement	21
Fig. 27 – Test setup 2 for intermodulation performance	22
Fig. 28 - BT Intermodulation Performance module	23
Fig. 29 - Test report: Intermodulation Performance	24
Fig. 30 - BT EDR C/I Performance module.....	26
Fig. 31 – Test report: EDR C/I Performance	27

Tables

Table 1 – C/I performance levels	14
Table 2 - Blocking performance: levels for 1st test run.....	17
Table 3 - Blocking performance: levels for 2nd test run.....	18
Table 4 – EDR C/I Performance for $\pi/4$ -DQPSK.....	25
Table 5 - EDR C/I Performance for 8DPSK	25

References

- [1] Bluetooth Test & Interoperability Working Group: **RF Test Suite Structure and Test Purposes System Specification 2.0 + EDR Revision 2.0.E.3**, 03/2005, Bluetooth SIG, Inc.
- [2] Rohde & Schwarz: **Manual for Windows Application CBTgo (V1.70)**,
- [3] Rohde & Schwarz: **Measurements on Bluetooth Products using R&S CMU200/CBT and CMUgo/CBTgo**, 1CM50_2E, 10/2006

5 Additional Information

Please send any comments and suggestions you may have regarding this application note to the following address:

TM-Applications@rsd.rohde-schwarz.com

Ordering information

Bluetooth Tester

R&S CBT with display, CBT 4 HU		1153.9000.35
R&S CBT without display, CBT32 19", 2 HU		1153.9000.32
Option B55	Hardware option: EDR Extension	1170.3006.02
Option U55	Hardware upgrade kit: EDR Extension	1170.3106.02
Option K55	Software option: EDR	1170.3206.02

Vector Signal Generators

R&S [®] SMU200A		1141.2005.02
R&S [®] SMU-B102	RF Path A: 100 kHz to 2.2 GHz	1141.8503.02
R&S [®] SMU-B103	RF Path A: 100 kHz to 3 GHz	1141.8603.02
R&S [®] SMU-B104	RF Path A: 100 kHz to 4 GHz	1141.8703.02
R&S [®] SMU-B106	RF Path A: 100 kHz to 6 GHz	1141.8803.02
R&S [®] SMU-B202	RF Path B: 100 kHz to 2.2 GHz	1141.9400.02
R&S [®] SMU-B203	RF Path B: 100 kHz to 3 GHz	1141.9500.02
R&S [®] SMU-B10	Baseband with ARB (64 Msamples)	1141.7007.02
R&S [®] SMU-B13	Baseband Main Module	1141.8003.02

Additional Information

Signal Generators

R&S [®] SMR20	1 GHz to 20 GHz	1104.0002.20
R&S [®] SMR-B11	0.01 GHz to 1 GHz	1104.4250.02
R&S [®] SMP02	2 GHz to 20 GHz	1035.5005.02

Signal Analyzers, Spectrum Analyzers and Options

R&S [®] FSP3	9 kHz to 3 GHz	1093.4495.03
R&S [®] FSP7	9 kHz to 7 GHz	1093.4495.07
R&S [®] FSP13	9 kHz to 13 GHz	1093.4495.13
R&S [®] FSP30	9 kHz to 30 GHz	1093.4495.30
R&S [®] FSP40	9 kHz to 40 GHz	1093.4495.40
R&S [®] FSQ3	20 Hz to 3.6 GHz	1155.5001.03
R&S [®] FSQ8	20 Hz to 8 GHz	1155.5001.08
R&S [®] FSQ26	20 Hz to 26.5 GHz	1155.5001.26
R&S [®] FSU3	20 Hz to 3.6 GHz	1166.1660.03
R&S [®] FSU8	20 Hz to 8 GHz	1166.1660.08
R&S [®] FSU26	20 Hz to 26.5 GHz	1166.1660.26
R&S [®] FSU46	20 Hz to 46 GHz	1166.1660.46
R&S [®] FSL3	9 kHz to 3 GHz	1300.2502.03
R&S [®] FSL6	9 kHz to 6 GHz	1300.2502.06



ROHDE & SCHWARZ GmbH & Co. KG · Mühldorfstraße 15 · D-81671 München · Postfach 80 14 69 · D-81614 München ·
Phone (089) 4129 -0 · Fax (089) 4129 - 13777 · Internet: <http://www.rohde-schwarz.com>

This application note and the software supplied may only be used subject to observance of the conditions of use set forth in the download area of the Rohde & Schwarz website.